

YAMAHA VMAX (2009)

SLIP-ON EXHAUST SYSTEM + OPTIONAL LINK PIPE

Our SLIP-ON system offers a great balance between price and performance, and represents the first step in the exhaust system tuning process. The change will also be visual as our special conical mufflers with CNC machined aluminum end caps, fit the exterior line of the VMAX perfectly and add a clean powerful image. The mufflers and link pipes with interference crossover tubes are entirely made of titanium, which gives a special hi-tech touch to our SLIP-ON system. You will save more than 10 kg and get more power compared to using a stock system. In addition to all of the above, the greatest improvement made was to the sound output. This combination is not legal for street use and comes also with removable noise dampers.

**We also offer additional noise dampers to lower noise emissions from 102 dB to 100 dB.*

PERFORMANCE

Measurements of the Akrapovič SLIP-ON OPEN system on the YAMAHA VMAX (with a muffler insert):

Power & Torque: The exhaust system modification results in a boost in performance, delivering a massive 186.26 HP at 9117 rpm on the back wheel. But the increased power is not available just at the top of the range; the system already exhibits its quality at 2000 rpm and up, through the top of the rpm range. The maximum power increase between the Akrapovič and the stock system is 7.4 HP at 7600 rpm. Additionally, the torque is substantially higher and will result in a smoother ride.



PERFORMANCE			
	stock	AKRAPOVIC	max. increased power
max. rear wheel power HP / rpm <small>(measured on SuperFlow Cycle Dyn)</small>	181.15 / 8995	186.26 / 9117	7.4 / 7600

ADDITIONAL DATA					
weight comparison (kg)	stock	AKRAPOVIC		difference	
	14.9	SS link pipe	TITANIUM link pipe	stock - S.S.	stock - TITANIUM
		-	4.78	-	10.12

noise measurements (dB / rpm)	stock	AKRAPOVIC
		92 / 4500
legal for street use	NO	

Technical specifications of Akrapovic exhaust systems and related products subject to change without notice.

Product code: (111368) S-Y17SO1-HBAV
 (111405) C-Y17SO1T/1 optional collector, (111431) V-TUV104SET optional noise damper set

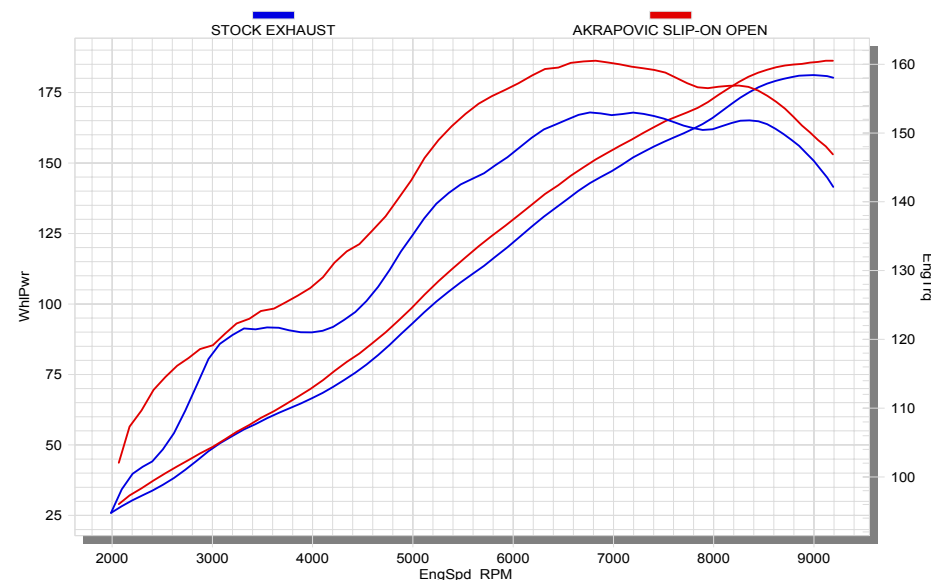

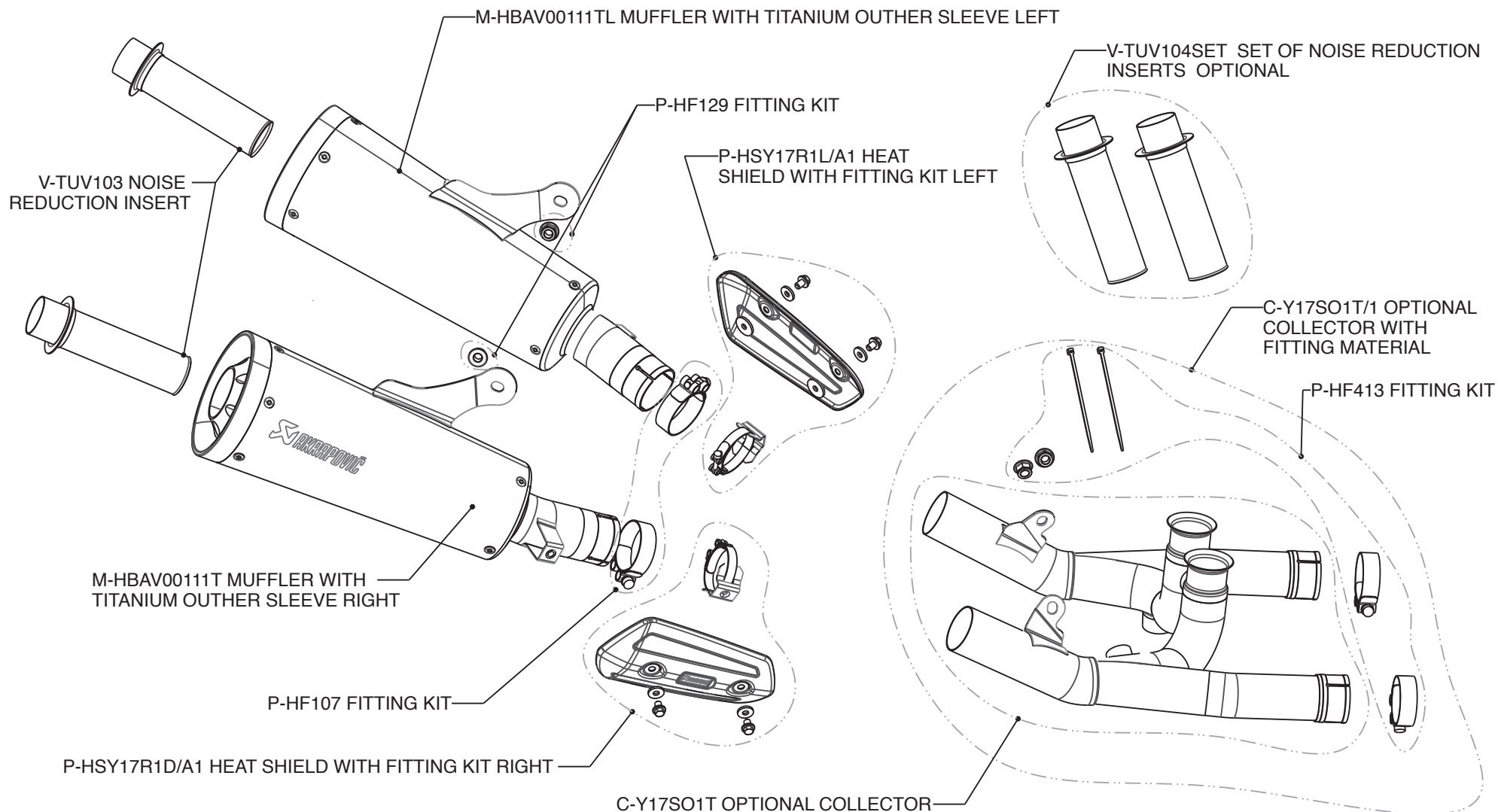

WARNING! IN COMBINATION WITH OPTIONAL COLLECTOR, THE SLIP-ON HOMOLOGATION IS NOT VALID!

Product code: (111368) S-Y17SO1-HBAV
 (111405) C-Y17SO1T/1 optional collector, (111431) V-TUV104SET optional noise damper set



www.akrapovic.com
 Akrapović d.d. 2009 all rights reserved
 27.07.2009